

Type / Table Bases

Collection / MA830

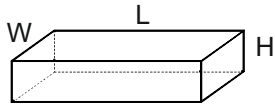
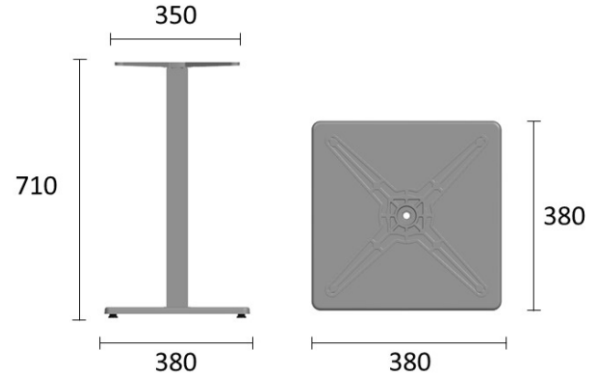

	Pcs/box	Length (cm)	Width (cm)	Height (cm)	Gross Weight (~ kg)	Net Weight (~ kg)	CBM m <sup>3</sup> /box
Base Box	1pcs/box	39,0	39,0	6,5	7,3	6,79	0,013
Column Box	1pcs/box	73	7	7			

## Material

- Column 60x60 mm Square Aluminum Extrusion
- Base & Cross Aluminum High Pressure Die Casting

Recyclable product



## Technical Information

- Outdoor
- Corrosion Resistance
- Adjustable table level for rough floors
- Precisely CNC machined
- Surface treatment processes
- Coated with electrostatic powder

## Coating

Electrostatic powder coating with certified class 1 high quality chemicals from top brands.

Color Options



## Certifications

Qualicoat Class 1: P-0145, P-0846, P-0673, P-0800, P-1661

GSB Florida 1: 171e

Marine CE 0575, CE 2690

- This powder coating complies with the European Directives "Restriction of the use of certain hazardous substances" 2011/65/EU and 2015/863/EU (RoHS)
- Meets the requirements of AAMA 2603-15
- Meets the requirements of EN 12206-1 (formerly BS 6496), EN 13438 (formerly BS 6497)
- Classification A2 (non flammable) of reaction to fire in accordance with NF EN 13501-1 + A1: 2013

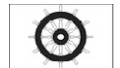

## Maintenance

It is recommended to clean the products regularly especially in humid or marine climate locations to keep them in good condition for a long time. Clean the surfaces using a soft cloth with water or mild detergents. Prolonged and continuous exposure to intense UV radiation from sunlight or very low temperatures can negatively affect the coating therefore to keep products in sheltered places during non-use periods is strongly recommended.